

NOTES:

1. SUBSTRATE MATERIAL:
FLOAT GLASS

2. COATING (APPLY ACROSS CLEAR APERTURE)

S1: R(avg) >85% @ 400 - 700nm

S2: NONE

3. ROHS COMPLIANT

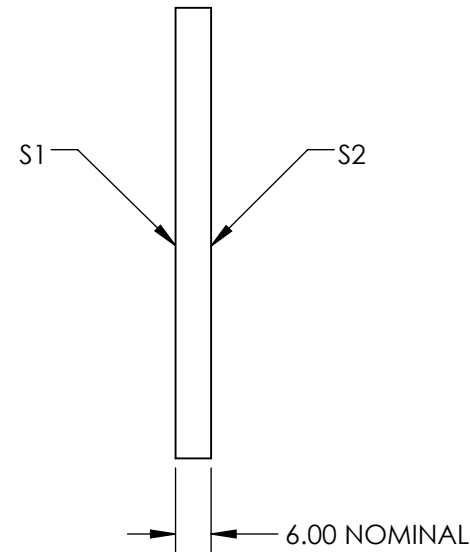
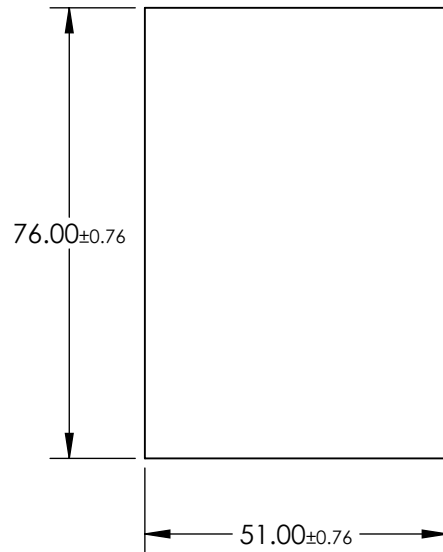
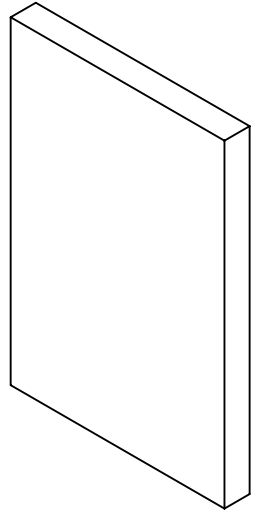

**FOR INFORMATION ONLY:
DO NOT MANUFACTURE
PARTS TO THIS DRAWING**

SPECIFICATIONS SUBJECT TO CHANGE WITHOUT NOTICE
DIMENSIONS ARE FOR REFERENCE ONLY

REV. A	S1	S2
SHAPE	PLANO	PLANO
ANGLE OF INCIDENCE	45°	N/A
SURFACE QUALITY	80-50	80-50
SURFACE FLATNESS	4 - 6λ	4 - 6λ
BEVEL	PROTECTIVE AS NEEDED	PROTECTIVE AS NEEDED

THIRD ANGLE
PROJECTION

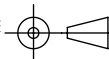

ALL DIMS IN

mm



TITLE	DWG NO	SHEET
51 x 76mm, 4-6λ Mirror	40040	1 OF 1